



NVE Challenger™ Series
Fan-Cooled
Liquid-Cooled
Packages

Heavy-duty vacuum pumps designed for extended use in liquid waste pumping systems.

CHALLENGER™ MODELS 607 & 866



National Vacuum Equipment

2670 Aero Park Drive
Traverse City, MI 49686 USA
800-253-5500 | sales@natvac.com

Arkansas Distribution Center

1612 Warehouse Drive
Fayetteville, AR 72701
479-409-7331, 479-409-6748 | Fax 479-444-8211

www.natvac.com

NVE Challenger™ Series – Fan-Cooled or Liquid-Cooled

Our Challenger™ Series pumps are designed and built with the customer in mind – resulting in dependable, high performing pumps that are easy to install, operate and service.

- Superior cooling for extended operations in severe conditions
- Heavy duty roller bearings
- Slotted end plate bolt holes for crash protection
- Precision-pinned end plates
- 4-point oiling system
- Vane wear inspection port
- Exhaust gas temperature gauge
- Diesel flush port
- High-strength ductile iron housing
- Air-injected ballast port cooling for extended use in deep vacuum (866)



607 Challenger™

Dimensions: 13 1/2" W x 31 5/8" L x 24 1/16" H

Weight: 395 Lbs.

Available in liquid-cooled and fan-cooled.

Recommended Setup for Optimum performance

RPM		Pressure (PSI)					Free flow					Vacuum (inches of Mercury)											
		20	15	10	5	0	5	10	15	20	25	27	23	23	22	21	20	19	19				
1500	Hp.	34	32	29	27	23	23	22	21	20	19	19	282	291	301	331	357	348	338	331	310	282	244
	CFM	229	237	244	269	290	282	275	269	252	229	198	25	24	23	20	20	19	16	15	14	14	14
1250	Hp.	29	27	24	23	20	20	19	16	15	14	14	229	237	244	269	290	282	275	269	252	229	198
	CFM	178	184	190	209	226	220	214	209	196	178	155	25	23	20	18	15	15	14	14	13	12	12
1000	Hp.	25	23	20	18	15	15	14	14	13	12	12	178	184	190	209	226	220	214	209	196	178	155
	CFM	178	184	190	209	226	220	214	209	196	178	155	25	23	20	18	15	15	14	14	13	12	12

1500 RPM Intermittent Operation only



866 Challenger™

Dimensions: 17 1/16" W x 30 1/16" L x 24 5/8" H

Weight: 507 Lbs.

Available in liquid-cooled and fan-cooled.

RPM		Pressure (PSI)					Free flow					Vacuum (inches of Mercury)																			
		25	20	15	10	5	0	3	6	9	12	15	18	21	24	27															
1150	Hp.	49	43	36	27	25	18	20	21	22	23	24	25	25	28	29	408	431	438	447	457	519	500	470	458	453	440	438	425	404	351
	CFM	355	375	381	389	398	452	435	409	399	394	390	381	370	352	306	43	38	32	24	20	15	17	18	19	20	21	22	23	24	25
1000	Hp.	43	38	32	24	20	15	17	18	19	20	21	22	23	24	25	355	375	381	389	398	452	435	409	399	394	390	381	370	352	306
	CFM	302	319	324	331	342	385	374	348	339	333	331	324	315	303	242	36	32	25	19	15	13	14	14	15	16	17	18	19	20	21
800	Hp.	36	32	25	19	15	13	14	14	15	16	17	18	19	20	21	302	319	324	331	342	385	374	348	339	333	331	324	315	303	242
	CFM	302	319	324	331	342	385	374	348	339	333	331	324	315	303	242	36	32	25	19	15	13	14	14	15	16	17	18	19	20	21

1150 RPM Intermittent Operation only

NVE Challenger™ Series Packages

NVE pioneered pump packages, and our engineering department continues to lead the industry in design and fabrication. We offer the most complete, easy to install packages available – allowing you to significantly reduce your engineering and installation time.

Packages are available in a variety of different setups including clockwise (CW) and counter-clockwise (CCW) rotations.

Standard Mounting Pak

Pallet weight: 607 - 565 Lbs.; 866 - 685 Lbs.

- Rugged, 3/8" construction, powder coat painted pump bracket
- Easy-align, adjustable gear box bracket
- 400 series three-shaft gear box accommodates CW and CCW rotation
- Coupler set with shear protection



607 and 866 Muffler Pak

Pallet weight: 607 - 644 Lbs.; 866 - 897 Lbs.

All the features included in the Standard Mounting Pak, plus:

- Compact designed square oil catch muffler
 - Effective baffle system
 - Stainless steel mesh filter
 - Drain valve
 - Exhaust deflector (other exhaust fittings available)
- All elbows, fittings and high temp hose are factory connected
- Right-hand or left-hand muffler location available



607 and 866 Max Pak

Pallet weight: 607 - 718 Lbs.; 866 - 999 Lbs.

All the features included in the Muffler Pak, plus:

- High efficiency aluminum moisture trap
 - Accessible 6" stainless steel float ball
 - BUNA positive shut-off ball seat
 - 2" lever drain valve
 - Blind intake flange standard (other fittings available)
- Vacuum/pressure relief valves and gauge



Self Contained Engine Drive Packages

Pallet weight: 607 - 1227 Lbs.

- Rugged, low-profile frame for belly-mount applications
- Deutz power unit with tachometer and LOFA control panel
- 23 gallon fuel tank
- High efficiency oil catch muffler
- Vacuum pressure relief manifold and gauge
- Powder coat painted and factory assembled



Hydraulic Motor Drives

- Heavy-duty two or four-bolt SAE flanged bracket
- Coupler set with automatic alignment
- Properly sized hydraulic motor



NVE Challenger™ Series Package Selection Guide

NVE makes it easy to select the pump package that is right for you. Choose from one of the setups shown, or contact our knowledgeable sales staff at 800-253-5500 or sales@nvepump.com.

607 CW "Max Pak" Assembly
116-607-MAX-D

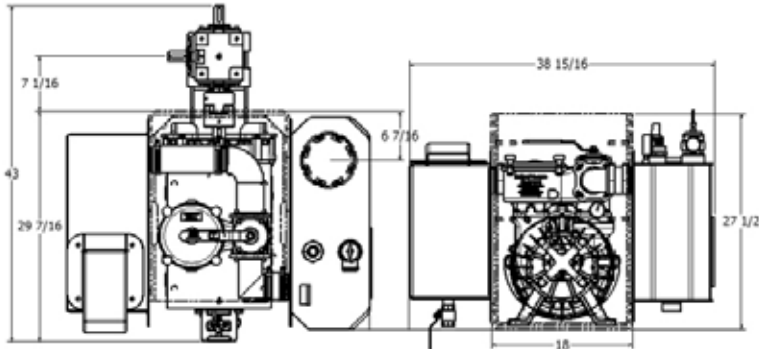

607 CW "Muffler Pak" Assembly
116-607-MUF-D

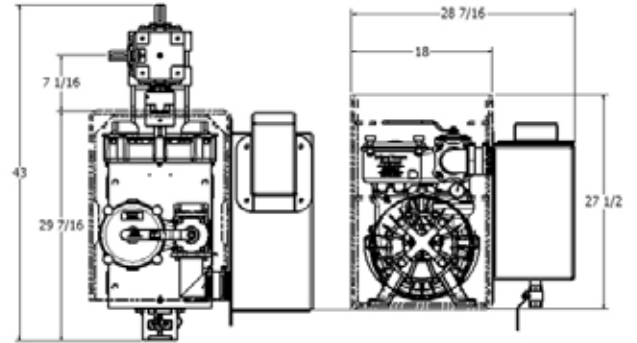

607 CCW "Max Pak" Assembly
116-607-MAX-S

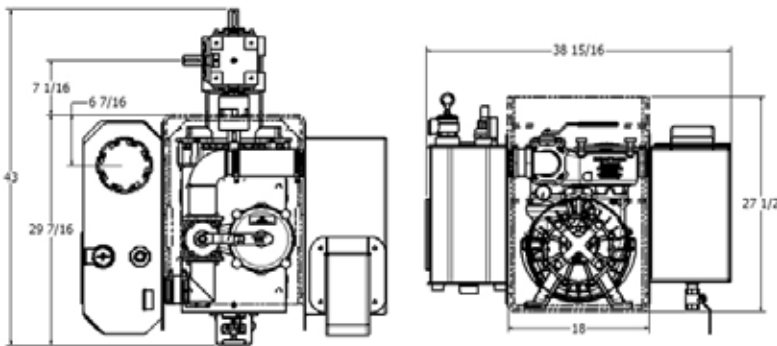

607 CCW "Muffler Pak" Assembly
116-607-MUF-S

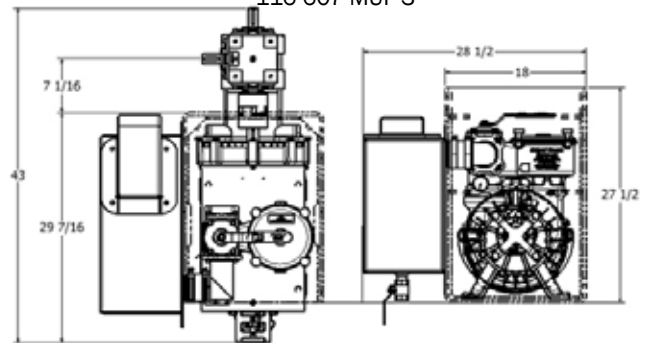

866 CW "Max Pak" Assembly
116-506-MAX-D

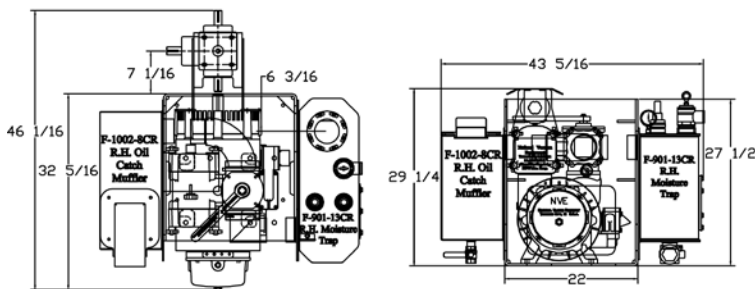

866 CW "Muffler Pak" Assembly
116-506-MUF-D

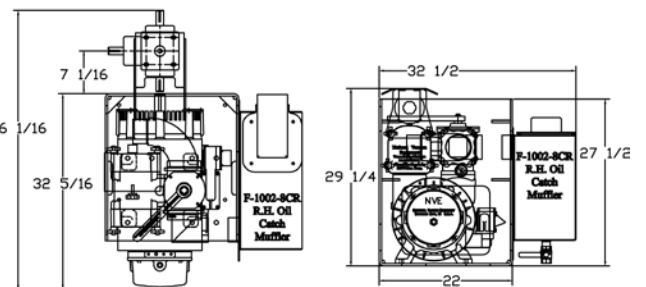

866 CCW "Max Pak" Assembly
116-506-MAX-S

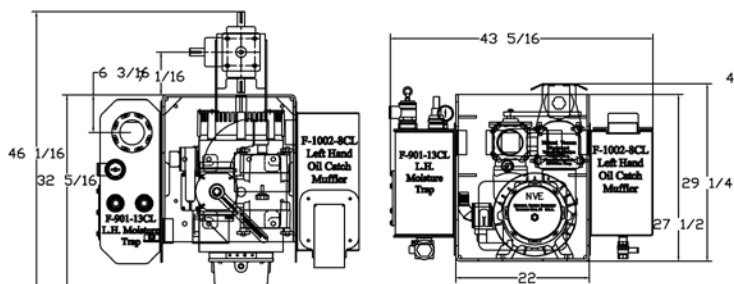

866 CCW "Muffler Pak" Assembly
116-506-MUF-S

